



M PROGRAMMER

New M programmer: push buttons to control temperature and time



OUTSTANDING FEATURES

Reversing drum action as standard
Stainless steel drum as standard
Frequency inverter as standard



EFFICIENCY

DOUBLE FLOW - mixed axial-radial airflow
Big fluff filter



VERSATILITY

Make to order - customisation
OPL > Multivending - Standard OPL model easily trasformable to coin laundry uses



ERGONOMICS

Drawer as fluff filter, stainless steel mesh
Biggest door diameters
Opening sense of door adjustable on site



MAINTENANCE

Hinged control panel: easy and ergonomic access
Technical menu: statistics for technicians and maintenance with external console (with console option)
Easy to access to components



OTHERS

Grey skinplate outer casing, stainless steel look
SOFT DRY - new drum with stamped holes
COOL DOWN - anti-wrinkle at the end of the cycle
Heating options: electric, gas and steam
CE approved



OPTIONS

- M programmer display



- Double doorglass
- Opposite door opening
- Back panel external air + filter
- Fluff filter with grid 0,6mm (standard is 0,3mm)
- Fluff filter with grid 1,2mm (standard is 0,3mm)
- Stainless steel front and side panels
- Front panel in stainless steel
- Steam battery in stainless steel
- Low pressure steam battery
- Reduced power (12kw instead of 18kw) for DTM 14
- Maritime wooden packing
- Ship voltage for electric models: 440V III 50/60 Hz No neutral
- Other voltages available

TECHNICAL DATA	UNIT.	DTM-11		DTM-14	
CAPACITY					
Capacity 1/18 // Capacity 1/20	Kg	11,7 // 10,5		15 // 13,5	
Hourly Output (electr. // gas)	Kg/h	20,3 // 28,6		26,9 // 30,3	
Evaporation capacity (electr. // gas)	l/h	9,3 // 14,5		13,5 // 15,4	
DRUM					
Ø Drum	mm	750		750	
Ø Door	mm	574		574	
Door center height	mm	976		976	
Load hole bottom height	mm	689		689	
Drum length	mm	475		610	
Drum volume	l	210		269	
POWER					
Drum motor power	kW	0,37		0,37	
Fan motor power	kW	0,25		0,25	
Electric heating power	kW	12		18	
Total electric power (elec.model)	kW	12,67		18,67	
Gas heating power	kW	20,51		20,51	
Instant propane gas consumption (G31)	kg/h	1,76		1,76	
Instant natural gas consumption (G20)	m3/h	2,17		2,17	
Total electric power (gas model)	kW	0,67		0,67	
Steam heating power	kW	30		30	
Total electric power (steam model)	kW	0,67		0,67	
CONNECTIONS					
		ELECTRICAL	GAS/STEAM	ELECTRICAL	GAS/STEAM
Tension 230V - I + N + T	Nº x mm2 / A	3 x 25 / 63A	3 x 1,5 / 20A	-	3 x 1,5 / 20A
Tension 230V - III + T	Nº x mm2 / A	4 x 10 / 40A	3 x 1,5 / 20A	4 x 16 / 63A	3 x 1,5 / 20A
Tension 400V - III + N + T	Nº x mm2 / A	5 x 4 / 25A	3 x 1,5 / 20A	5 x 10 / 32A	3 x 1,5 / 20A
Ø Gas inlet	BSP	1/2"		1/2"	
DIMENSIONS / PACKING DIMENSIONS					
Net width / Gross width	mm	785 / 865		785 / 865	
Net Depth / Gross Depth	mm	855 / 940		989 / 1074	
Net Height / Gross Height	mm	1694 / 1840		1694 / 1840	
Height without heating battery	mm	-		-	
Net weight / Gross weight	Kg	172 / 180		180 / 190	
OTHERS					
Max airflow	m3/h	850		850	
Ø Fume exhaust	mm	200		200	
Sound level	dB	64		64	

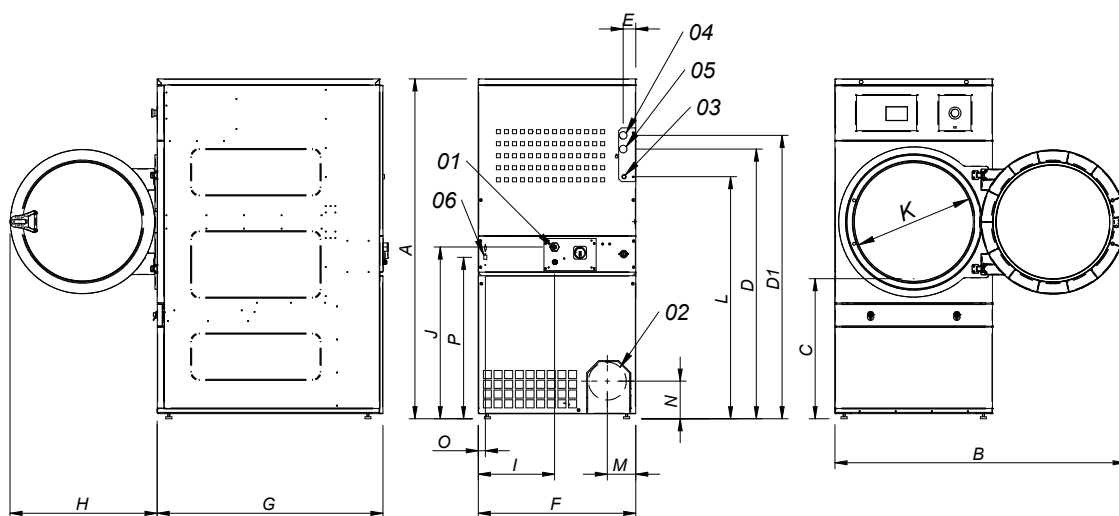

- 01 POWER SUPPLY
- 02 FUMES OUTPUT Ø200
- 03 GAS INLET 1/2"
- 04 STEAM INLET 3/4"
- 05 CONDENSATE OUTLET 3/4"
- 06 ETHERNET CONNECTION (only available CONTROL TOUCH II models)

	A	B	C	D	D1	E	E1	F	G	H	I	J	K	L	M	N	O	P
DTM-11	1694*	1447	689	1354	1422	68	68	785	855	735	380	870	575	1226	133	180	35	805
DTM-14	1694*	1447	689	1354	1422	68	68	785	989	735	380	870	575	1226	133	180	35	805

* Measurement with legs mounted (30mm)