



M PROGRAMMER

New M programmer: push buttons to control temperature and time



OUTSTANDING FEATURES

Reversing drum action as standard
Stainless steel drum as standard
Frequency inverter as standard



EFFICIENCY

DOUBLE FLOW - mixed axial-radial airflow
Big fluff filter



VERSATILITY

Make to order - customisation



ERGONOMICS

Drawer as fluff filter, stainless steel mesh
Biggest door diameters



MAINTENANCE

Hinged control panel: easy and ergonomic access
Technical menu: statistics for technicians and maintenance with external console (with console option)
Easy to access to components



OTHERS

Steam battery in stainless steel (up to 15 bar pressure)
Grey skinplate outer casing, stainless steel look
SOFT DRY - new drum with stamped holes
COOL DOWN - anti-wrinkle at the end of the cycle
Heating options: electric, gas and steam
CE approved



OPTIONS

- NEW Automatic or manual sliding door
- Double doorglass
- Opposite door opening
- Back panel external air + filter
- Fluff filter with grid 0,6mm (standard is 0,3mm)
- Fluff filter with grid 1,2mm (standard is 0,3mm)
- Stainless steel front and side panels
- Front panel in stainless steel
- Low pressure steam battery
- Maritime wooden packing
- Ship voltage for electric models:
440V III 50/60 Hz No neutral
- Other voltages available

TECHNICAL DATA	UNIT.	DTM-45	DTM-60	DTM-80			
CAPACITY							
Capacity 1/18 // Capacity 1/20	Kg	49,8 // 44,8	66,8 // 60,1	83,3 // 75,0			
Hourly Output (electr. // gas)	Kg/h	80,4 // 84,4	120 // 128,60	128,6 // 173,10			
Evaporation capacity (electr. // gas)	l/h	40,2 // 42,5	60,2 // 65,8	64 // 86,5			
DRUM							
Ø Drum	mm	1225	1225	1225			
Ø Door	mm	802	802	802			
Door center height	mm	1275	1275	1275			
Load hole bottom height	mm	874	874	874			
Drum length	mm	760	1020	1252			
Drum volume	l	896	1202	1500			
POWER							
Drum motor power	kW	0,75	1,1	1,5			
Fan motor power	kW	1,1	1,1	1,1			
Electric heating power	kW	54	72	72			
Total electric power (elec.model)	kW	55,9	74,25	74,65			
Gas heating power	kW	60	90	120			
Instant propane gas consumption (G31)	kg/h	5,14	7,71	10,28			
Instant natural gas consumption (G20)	m3/h	6,35	9,53	12,71			
Total electric power (gas model)	kW	1,9	2,25	2,65			
Steam heating power	kW	91,3	128	128			
Total electric power (steam model)	kW	1,9	2,25	2,65			
CONNECTIONS		ELECTRICAL	GAS/STEAM	ELECTRICAL	GAS/STEAM	ELECTRICAL	GAS/STEAM
Tension 230V - I + N + T	Nº x mm2 / A	-	-	-	-	-	-
Tension 230V - III + T	Nº x mm2 / A	-	4 x 2,5 / 20A	-	4 x 2,5 / 32A	-	4 x 2,5 / 32A
Tension 400V - III + N + T	Nº x mm2 / A	5 x 35 /100A	5 x 1,5 / 20A	5 x 50 /125A	5 x 1,5 / 32A	5 x 50 /125A	5 x 1,5 / 32A
Ø Gas inlet	BSP	3/4"		3/4"		3/4"	
DIMENSIONS / PACKING DIMENSIONS							
Net width / Gross width	mm	1.270/1.330		1.270/1.330		1.270/1.330	
Net Depth / Gross Depth	mm	1.106/1.185*		1.366/1.445		1.598/1.705	
Net Height / Gross Height	mm	2.380/2.150		2.380/2.150		2.380/2.150	
Height without heating battery	mm	1950		1950		1950	
Net weight / Gross weight	Kg	395/430		529/575		657/715	
OTHERS							
Max airflow	m3/h	3.000		3.000		3.000	
Ø Fume exhaust	mm	300		300		300	
Sound level	dB	67		67		67	

* Gas or steam model, same size as the 80kg one (incorporates batteries in the back)

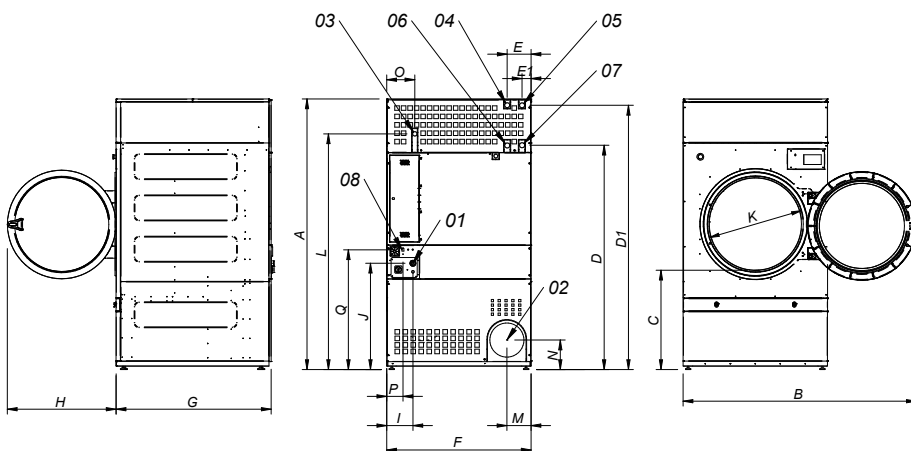

	A	B	C	D	D1	E	E1	F	G	H	I	J	K	L	M	N	O	P	Q
DTM-45	2380*	2045	874	1981	2311	211	80	1270	1106	956	248	935	802	2088	214	240	244	160	1053
DTM-60	2380*	2045	874	1981	2311	211	80	1270	1366	956	248	935	802	2088	214	240	244	160	1053
DTM-80	2380*	2045	874	1981	2311	211	80	1270	1598	956	248	935	802	2088	214	240	244	160	1053

* Measurement with legs mounted (30mm)